

SHOW CHROME®**INSTALLATION INSTRUCTIONS**

Copyright© 2023 by Big Bike Parts, Inc. No part of this instruction sheet may be reproduced without the written permission of Big Bike Parts, Inc.

PART NO.:

41-416C/41-416CRED
41-416GC/41-416GCRED

DESCRIPTION:

BALLISTIC DRIVER BACKREST &
GRANDE DRIVER BACKREST**ESTIMATED INSTALLATION TIME: 30 TO 60 MIN.**

FITMENT:

CAN AM RYKER 2019+ NEWER

TOOLS NEEDED:

T30 TORX

10MM WRENCH

5MM ALLEN WRENCH

REMOVABLE THREAD LOCK

5MM ALLEN WRENCH

7/16" WRENCH

T25 TORX

T30 TORX

RAZOR KNIFE

PLEASE READ THROUGH AND UNDERSTAND THESE INSTRUCTIONS BEFORE BEGINNING. *USE REMOVABLE THREAD LOCK ON ALL FASTENERS***INSTALLATION WITHOUT MAX MOUNT INSTALLED:**

- 1A. USING A T25 REMOVE THE 6 SCREWS SHOWN IN FIG. 1A. (LH SIDE CAP SCREWS ARE OPPOSITE OF RH SIDE CAP SCREWS) REMOVE BOTH SIDE CAPS AND THE REAR SPOILER FROM THE BIKE. **NOTE: IF YOU HAVE THE SHAD BAG MOUNT INSTALLED, IT WILL NEED TO BE UNINSTALLED BEFORE REMOVING THE REAR SPOILER. STEPS 2A THROUGH 5A ARE OPTIONAL IF YOU WISH TO USE THE REAR SPOILER.**
- 2A. PLACE A PIECE OF MASKING TAPE ON THE REAR SPOILER AND MARK THE RECTANGLE LINES TO CUT. (FIG. 2A)
- 3A. CAREFULLY CUT THROUGH BOTH LAYERS OF THE REAR SPOILER. BE SURE TO REMOVE ANY SHARP EDGES FROM CUTTING.
- 4A. INSTALL THE REAR SPOILER, LH SIDE CAP AND RH SIDE CAP IN REVERSE ORDER AND TIGHTEN THE 6 SCREWS FROM STEP 1. **BE SURE NOT TO OVER TIGHTEN THE SCREWS.**
- 5A. CONTINUE TO THE STEPS BELOW FOR THE REST OF THE BACKREST INSTALL.

INSTALLATION WITH MAX MOUNT FENDER:

- 1B. REMOVE THE RIGHT-SIDE SEAT PANEL BUT PULLING STRAIGHT OUT ON THE TOP (FIG. 1B) TO RELEASE IT FROM THE RUBBER GROMMETS IN THE SEAT, AND THEN PULL STRAIGHT UP TO REMOVE. SET ASIDE FOR NOW. REPEAT ON THE LEFT SIDE SEAT PANEL.
- 2B. USE A T40 TORX TO REMOVE THE FOUR BOLTS (2 ON EACH SIDE) SECURING THE MAX MOUNT (FIG. 2B).
- 3B. SLIDE THE MAX MOUNT BACK TOWARDS THE REAR OF THE VEHICLE TO REMOVE (FIG. 2B). SET ON A CLEAN SURFACE UPSIDE DOWN.
- 4B. PLACE MASKING TAPE TO THE UNDER SIDE OF THE FENDER ACCORDING TO FIG. 3B.
- 5B. REMOVE THE FOUR SCREWS SECURING THE FENDER TO THE MAX MOUNT (FIG. 3B).
- 6B. SLIDE THE FENDER TOWARDS THE FRONT OF THE MAX MOUNT TO REMOVE (FIG. 3B).
- 7B. MARK THE FENDER ACCORDING TO FIG. 4B.
- 8B. CAREFULLY CUT THE FENDER ALONG THE MARK FROM STEP 7B USING A RAZOR KNIFE.
- 9B. REPEAT STEPS 1B THROUGH 6B IN REVERSE ORDER TO REINSTALL THE MAX MOUNT AND FENDER ON THE VEHICLE.

INSTALLATION WITH MAX MOUNT INSTALLED:

1. **IF INSTALLING ON A RYKER SPORT OR RYKER RALLY, SEE "INSTALLATION WITH MAX MOUNT FENDER" SECTION ABOVE FIRST.**
2. USE A T30 TORX TO REMOVE THE TWO OEM SEAT SCREWS SHOWN IN FIG. 1 LOCATED UNDER THE SEAT (THESE SCREWS WILL NOT BE REUSED).
3. REMOVE THE BACKREST BASE MOUNT AND THE BACKREST RISER ASSEMBLY FROM THE PACKAGE (FIG. 2).
4. PLACE A SMALL DROP OF REMOVABLE THREAD LOCK TO THE ENDS OF THE TWO M8 X 14MM LONG SCREWS AND INSTALL THEM INTO THE BASE MOUNT AS SHOWN IN FIG. 2. DO NOT TIGHTEN YET. **NOTE: THERE ARE TWO HEIGHT POSITIONS. USE THE TOP TWO HOLES IN THE BASE MOUNT FOR A TALLER BACKREST, USE THE BOTTOM TWO HOLES FOR A LOWER BACKREST. FIG. 2 SHOWS THE LOWER POSITION.**
5. INSTALL THE SUPPLIED RISER IN PLACE ON THE TWO SCREWS AS SHOWN IN FIG. 2. USING A 5MM ALLEN WRENCH, ADJUST AND TIGHTEN THE SCREWS SO THAT THE HEAD OF THE SCREW IS AS CLOSE AS POSSIBLE TO THE RISER BUT THE RISER WILL STILL SLIDE OFF OF THE SCREWS. REMOVE THE RISER FROM THE BASE MOUNT AND SET ASIDE FOR NOW.
6. PLACE THE BACKREST BASE MOUNT IN POSITION UNDER THE SEAT AND INSTALL THE TWO M6 X 25MM SOCKET HEAD SCREWS AND LOCK WASHERS IN THE HOLES THAT YOU REMOVED THE SCREWS IN STEP 1 (FIG. 3). **FINGER TIGHTEN ONLY, DO NOT TIGHTEN COMPLETELY.**
7. INSTALL TWO M8 X 40MM BUTTON HEAD SCREWS, FLAT WASHERS, SPACERS AND NYLOCK NUTS ACCORDING TO FIG. 3. TIGHTEN THESE COMPLETELY WHILE PUSHING THE BASE MOUNT UP TIGHT UNDER THE FRAME/SEAT. **NOTE: IF YOU HAVE A SHAD BAG MOUNT INSTALLED, THE TWO SCREWS AND CLIP NUTS MUST BE REMOVED BEFORE INSTALLING THE M8 X 40MM SCREWS.**
8. FINISH TIGHTENING THE TWO SCREWS FROM STEP 5. **DO NOT OVER TIGHTEN SCREWS.**
9. REMOVE THE REST OF THE PARTS FROM THE PACKING.
10. ASSEMBLE THE BACKREST PAD ASSEMBLY ONTO THE BACKREST RISER ASSEMBLY ACCORDING TO FIG. 4.
11. INSTALL THE BACKREST ASSEMBLY FROM STEP 9 ONTO THE MOUNT BASE INSTALLED ON THE BIKE.

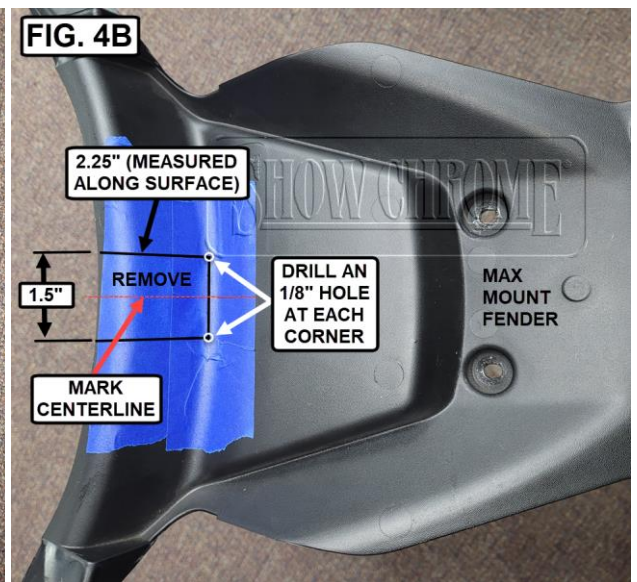
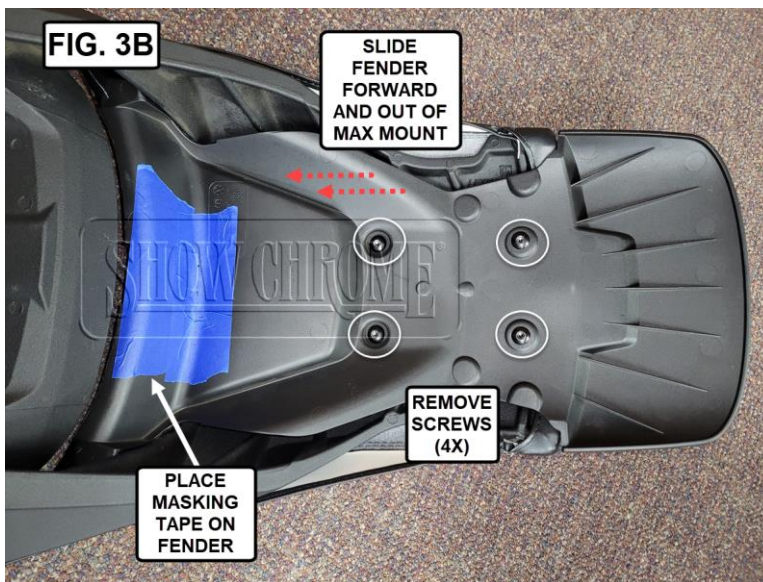
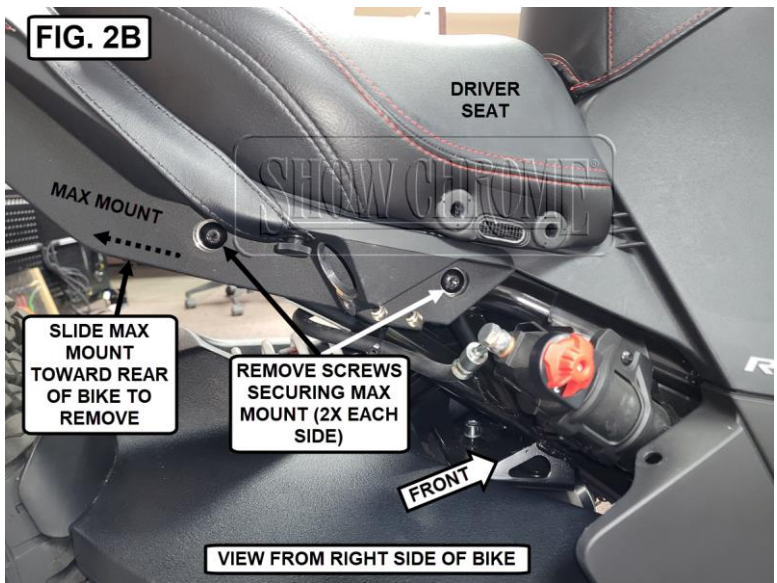
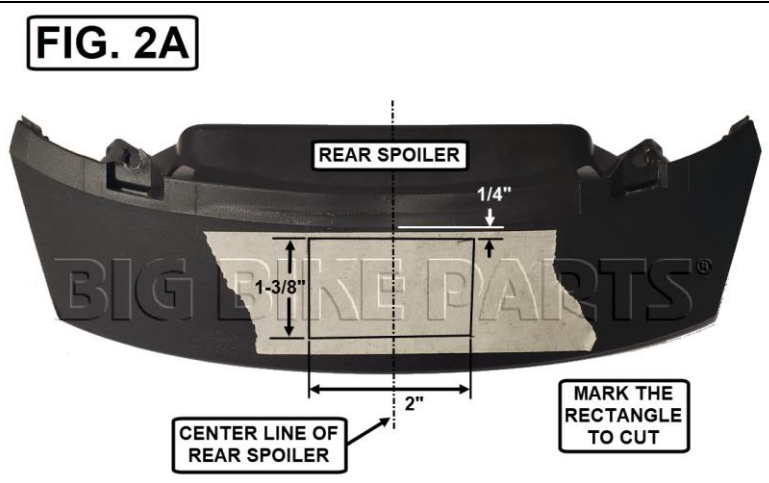
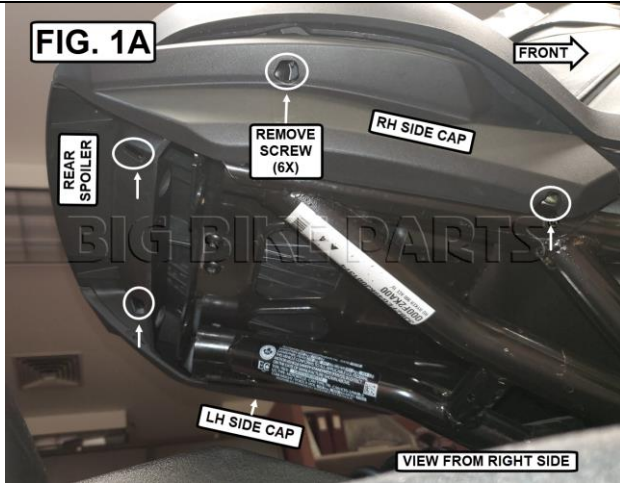

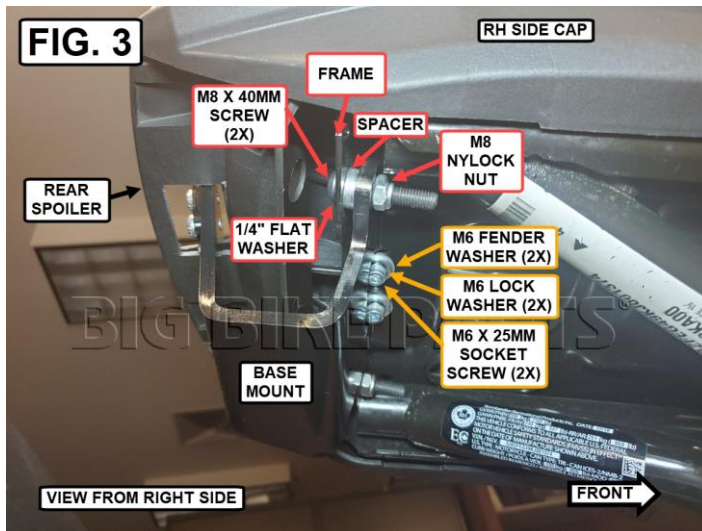
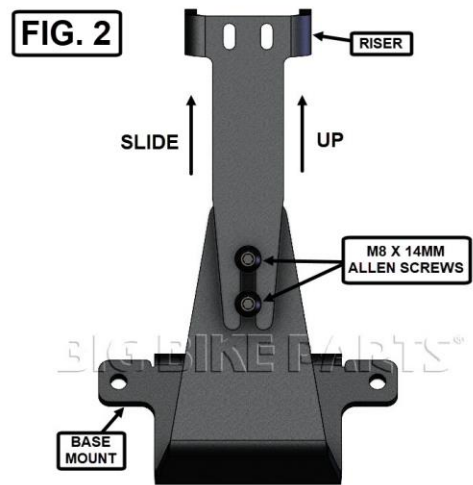
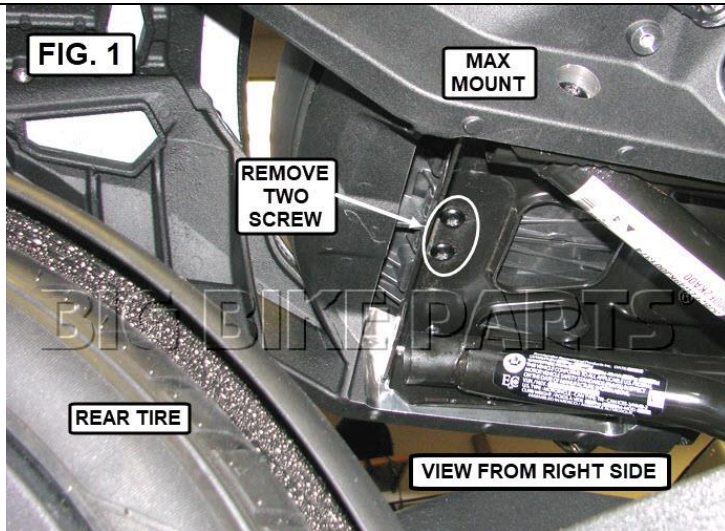

WARNING

BACKREST IS DESIGNED TO SUPPORT RIDERS LOWER BACK WHEN RIDING. DO NOT APPLY EXCESSIVE FORCE BY PUSHING BACK WITH YOUR FULL BODY WEIGHT. DO NOT USE BACKREST TO LIFT OR SUPPORT MOTORCYCLE.

NOTICE

IGNORING THE CONTENTS OF THESE INSTRUCTIONS MAY AFFECT THE PRODUCT PERFORMANCE AND FUNCTIONALITY. NOT FOLLOWING THESE INSTRUCTION MAY CAUSE DAMAGE TO THE PRODUCT OR THE VEHICLE TO WHICH IT IS BEING ATTACHED.