

Copyright © 2019 by Big Bike Parts, Inc. No part of this instruction sheet may be reproduced without the written permission of Big Bike Parts, Inc.

PART NO. 41-403WI

ACCESSORY SUB HARNESS

1/8/2020

FITMENT:

CAN-AM RYKER 2019-NEWER

TOOLS NEEDED:

T30 TORX

T20 TORX

PUSH PIN PLIERS

WIRE CUTTER/CRIMPER

PLEASE READ THROUGH AND UNDERSTAND THESE INSTRUCTIONS BEFORE BEGINNING.

ESTIMATED INSTALLATION TIME: 30 TO 45 MIN.

BIG BIKE PARTS RECOMMENDS INSTALLING AN ELECTRONIC FUSE BLOCK (PART NO. 13-311) BEFORE CONNECTING ANY ADDED ELECTRICAL ACCESSORIES TO THE BIKE.

INSTALLATION:

1. STARTING AT THE REAR OF THE RYKER, REMOVE THE SCREW HOLDING THE REAR FENDER TRIM (FIG. 1).
2. LIFT THE FRONT OF THE REAR FENDER TRIM TO RELEASE IT FROM THE RUBBER GROMMETS AND SLIDE IT BACK TO REMOVE (FIG. 2).
3. REMOVE THE THREE SCREWS HOLDING THE LEFT TAIL LIGHT (FIG. 3 & FIG. 4).
4. REMOVE THE LEFT TAIL LIGHT AND DISCONNECT THE TAIL LIGHT WIRE HARNESS.
5. REPEAT STEPS 3 AND 4 ON THE RIGHT SIDE.
6. REMOVE THE TWO PUSH PINS HOLDING THE LEFT SIDE PANEL SHOWN IN FIG 5.
7. PULL THE LEFT SIDE OF THE FRONT FASCIA EXTENSION OUTWARD SLIGHTLY (FIG. 6). WHILE HOLDING OUTWARD, PULL THE TAB ON THE END OF THE FRONT FASCIA EXTENSION OUT TO RELEASE AND PULL IT FORWARD TO RELEASE (FIG. 6).
8. REMOVE THE PUSH PIN HOLDING THE FRONT OF THE LEFT SIDE PANEL (FIG. 7).
9. PULL THE FRONT OF THE LEFT SIDE PANEL STRAIGHT OUTWARD TO RELEASE THE METAL CLIP (FIG. 7).
10. PULL THE REAR OF THE LEFT SIDE PANEL OUT TO RELEASE THE TAB AND SLIDE THE SIDE PANEL FORWARD TO REMOVE.
11. REMOVE THE SUB-HARNESS FROM THE KIT AND DETERMINE THE LEFT AND RIGHT CONNECTORS (FIG. 9).CONNECT THE SUPPLIED SUB-HARNESS TO THE TAIL LIGHT HARNESSES ACCORDING TO FIG. 8 & FIG. 9.
12. RUN THE SUB-HARNESS ALONG THE OEM TAIL LIGHT HARNESS UNDER THE LEFT SIDE OF THE RYKER TOWARDS THE FRONT. *USE WIRE TIES TO SECURE AS NEEDED. (BE SURE SUB-HARNESS IS SECURED AWAY FROM THE REAR WHEEL OR ANY MOVING PARTS.)*
13. REFERENCE FIG 9 TO CONNECT ACCESSORIES TO THE SUB HARNESS.
14. REASSEMBLE THE RYKER IN REVERSE ORDER.

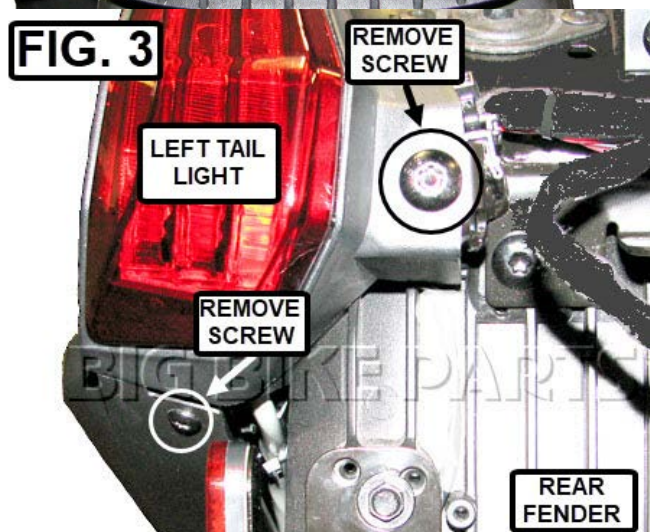
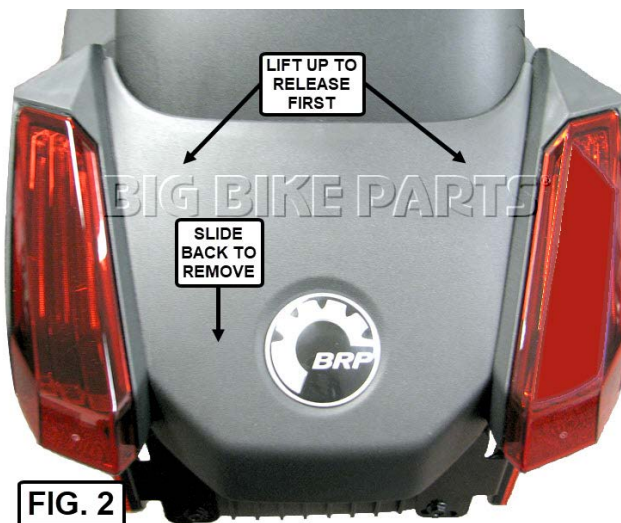

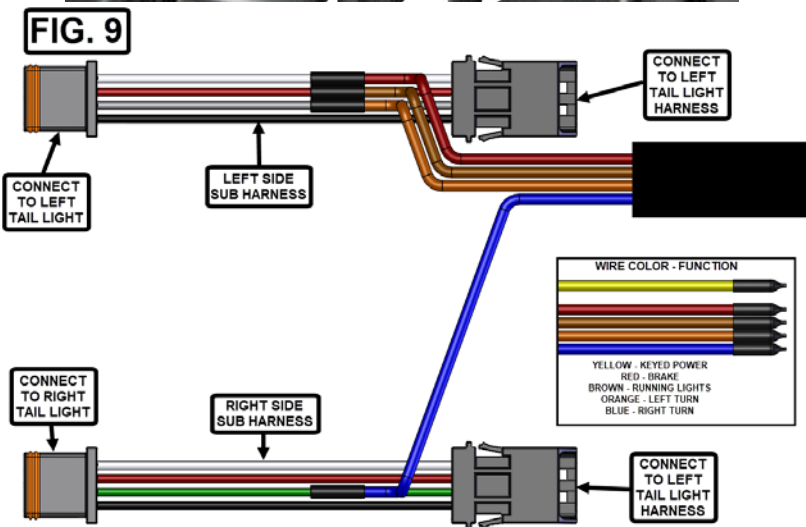
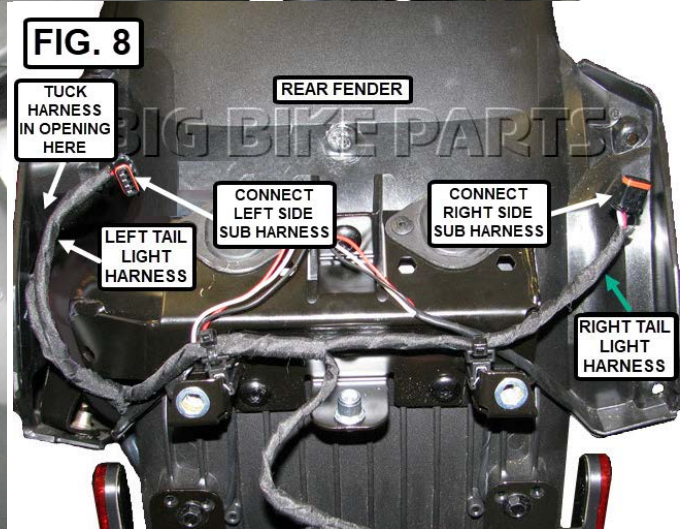
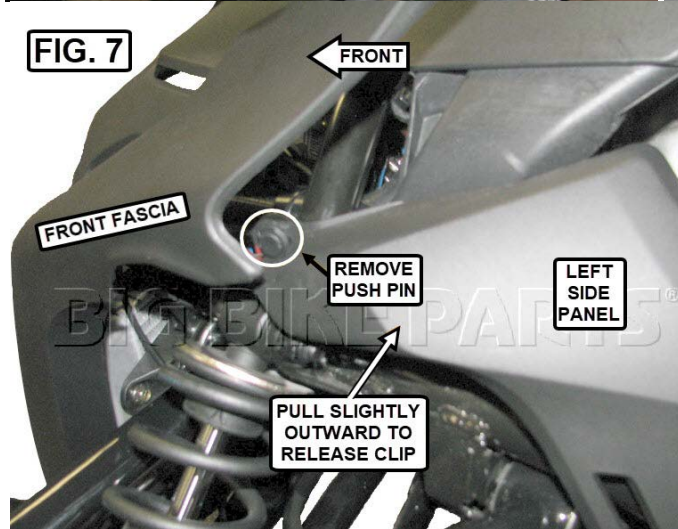
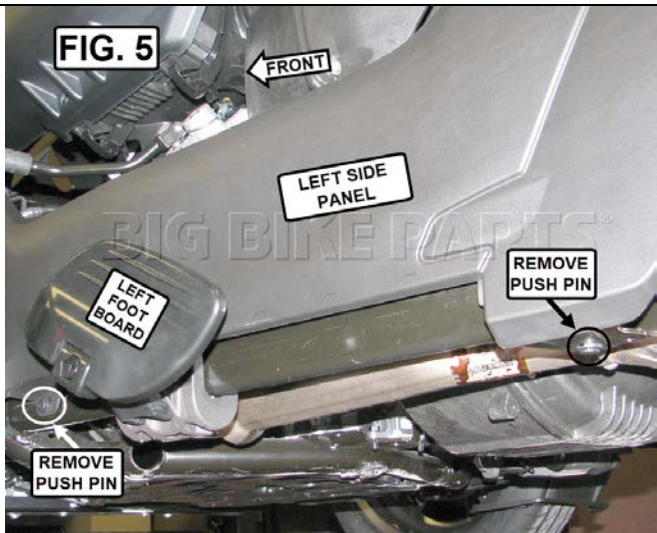

NOTICE

IGNORING THE CONTENTS OF THESE INSTRUCTIONS MAY AFFECT THE PRODUCT PERFORMANCE AND FUNCTIONALITY. NOT FOLLOWING THESE INSTRUCTION MAY CAUSE DAMAGE TO THE PRODUCT OR THE VEHICLE TO WHICH IT IS BEING ATTACHED.

NOTICE

CAN-AM RYKER

BIG BIKE PARTS RECOMMENDS INSTALLING AN ISOLATION FUSE BLOCK (PART NUMBER 41-403) BEFORE CONNECTING ANY ADDED ELECTRICAL ACCESSORIES TO THE RYKER.